

Selection Guide | VLT® Midi Drive FC 280

Flexible. Communicative.
Easy to use.
..fits your application



**The
right mix**

of features gives you
freedom to achieve
your system goals

Access your **true high-efficiency potential...**

Reach new levels of performance with the VLT® Midi Drive FC 280, the evolution of the popular VLT® 2800 drive. Profit from new savings, with a wide range of features designed to make installing, using and maintaining the AC drive as simple and as easy as possible. Just set it and forget it.

For precise and efficient motor control for machine builders in the food and beverage, material handling and processing industries, the VLT® Midi Drive is ideal. It is strong on control performance, functional safety, and flexible fieldbus communication.

The right mix of features ensures the AC drive suits your task, whether for conveyor systems, mixers, and packaging systems or driving pumps, fans and compressors.

With all-pluggable connectors, integrated DC choke, RFI filter, and dual-channel STO functional safety, the drive is easy to use and there are no hidden extras.

The VLT® Midi Drive provides

- Easy and fast installation and set-up
- Savings on cost and space
- Flexibility – to suit your task

...giving you the freedom to achieve your system goals.

Set and forget

Built on the success and experience of more than 45 years in the drives field, the VLT® Midi Drive shares the same technical heritage represented by the VLT® name in AC drives.

Easy retrofit

VLT® Midi Drive is prepared for compatibility with the VLT® 2800, for a fast, streamlined retrofit.



Therefore you can rely on the same low-maintenance robustness and reliability – once you have set it, it will run reliably, earning you energy savings for years on end.

Freedom from extra components

- With integrated DC choke for harmonics mitigation there are no additional component costs.
- The built-in RFI disconnect switch minimizes leakage current and optimizes safe operation on IT mains – as standard.

- VLT Midi Drive is designed to operate at 45-50°C ambient temperature at full load and 55°C with derating. This capability means that there is no need to install extra cooling equipment or oversize the drive.

These integrated features save you overdimensioning, additional purchases and save space too, delivering cost savings to your project.

Compact design for easy installation

The compact design, and side by side mounting with zero clearance between the drives, make it simpler to optimize panel space.



Flexible. Easy to use.

Easy retrofit

VLT® Midi Drive is prepared for compatibility with the VLT® 2800. Its exterior dimensions, cable plugs, cable lengths, and set-up software tools enable easy retrofit in established plant or machinery concepts.

Service friendly

The VLT® Memory Module MCM 102 facilitates helpful implementation of factory settings for OEM and machine builders, fast installation of firmware updates, and easy commissioning or exchange of drives – a first for VLT® drives.

Simply use your PC to copy the drive settings from one VLT® Memory Module to another.

Save time on set-up

Numeric or graphical LCP

Easy parameter set-up makes the path to energy savings both short and simple, via an enhanced numeric LCP or graphical control panel that supports seven languages.

Targeted 'Application Selections' make it easy for users to set up and commission typical applications.

VLT® Motion Control Tool MCT 10

Configure and monitor the FC 280 with Danfoss' own VLT® Motion Control Tool MCT 10 software. This tool provides plant managers with a comprehensive overview over the system at any point in time and a high level of flexibility in configuration and monitoring. There is even a USB port enabling fast PC connection for commissioning and troubleshooting.

All-pluggable

Pluggable terminals make this the easiest wiring task imaginable for installation and service – simply plug in and plug out for mains, RS485, I/O, and motor connections.



The VLT® Memory Module facilitates helpful implementation of factory settings, fast installation of firmware updates, and easy transfer of settings.



Features and benefits

Feature	Benefit
Integrated harmonics and EMC design	
Integrated DC choke	<ul style="list-style-type: none"> – Saves installation time and panel space requirements – Improves power supply quality and helps extend DC capacitor lifetime
Integrated EMC filter	<ul style="list-style-type: none"> – Avoids malfunction and improves reliability of surrounding components
RFI switch	<ul style="list-style-type: none"> – Operates safely on IT mains – Trouble-free operation of insulation monitoring relay
Easy to install and set up	
Pluggable terminals	<ul style="list-style-type: none"> – Fast installation and unit exchange
USB port	<ul style="list-style-type: none"> – Easy PC connection for troubleshooting or commissioning – No need for adapter or PC-USB driver
Application set-up wizards	<ul style="list-style-type: none"> – Easy commissioning
Memory module (option)	<ul style="list-style-type: none"> – Convenient transfer of parameter set-up – Easy firmware updates – Easy and fast commissioning
Memory module programmer (option)	<ul style="list-style-type: none"> – Convenient transfer files to and from the VLT® Memory Module MCM 102 via PC
Enhanced numerical LCP (option)	<ul style="list-style-type: none"> – Cost effective user interface
Adapter for graphical LCP supporting many languages (option)	<ul style="list-style-type: none"> – Easy set-up in one of seven main languages – Fast troubleshooting
Strategic design for applications, safety, and motor control	
Integrated Safe Torque Off (STO), dual channel	<ul style="list-style-type: none"> – Eliminates external components – Enables reliable functional safety
Control algorithm runs both induction and PM motors	<ul style="list-style-type: none"> – Freedom to choose the best high-efficiency motor for the task
Integrated brake chopper for 3-phase drives in power sizes up to 22 kW	<ul style="list-style-type: none"> – No cost for external braking chopper
Side-by-side or horizontal mounting, without derating	<ul style="list-style-type: none"> – Saves panel space and cost
Operates at up to 45 °C without derating	<ul style="list-style-type: none"> – Saves cost for external cooling and reduces downtime for overtemperature failures





Fits your application

This drive delivers ease of use and high flexibility in food and beverage industries, material handling, and processing industries.

The right mix of features is the key to optimizing performance for your task, for

Conveyor systems

Release the conveyor from mechanical stress via controlled acceleration and deceleration – promoting longer life and lower operating costs.

Mixers

Upgrade from VLT® 2800, free of redesign – the VLT® Midi Drive fits perfectly. Even upgrade to the high-efficiency motor of your choice – VLT® Midi Drive is compatible.

Packaging systems

Profit from compact size and integrated harmonics mitigation, with STO to comply with industrial machine standards.

Pumps

Benefit from reliable operation together with integrated EMC filter and harmonics mitigation.

Fans

Achieve up to 50% energy savings by a 20% reduction in fan speed, and save on carbon emissions too.

Compressors

Enjoy built-in functional safety and the fieldbus protocol of your choice, whilst optimizing performance coefficient.

Integrated DC choke
reduces harmonics
to less than
48%
THDi



Designed to meet industrial needs

Choose the VLT® Midi Drive, whatever your task is. A broad range of fieldbus options suits protocol standards of many different industries. International certification includes CE and UL.

Because it's compatible with both induction and PM motors, you also win the freedom to choose the best high-efficiency motor for your task.

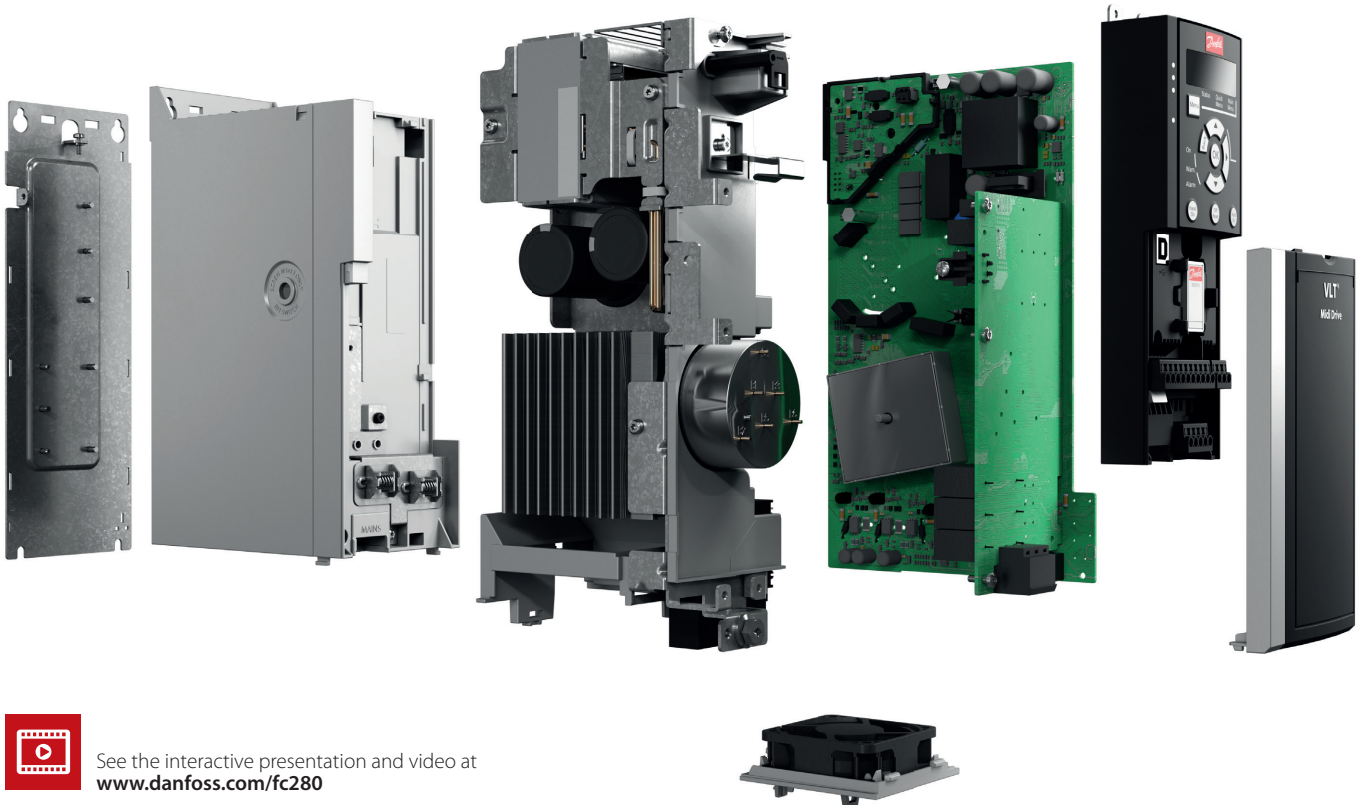

See the interactive presentation and video at www.danfoss.com/fc280

Integrated DC chokes

- Integrated DC chokes reduce harmonics to less than 48% THDi in compliance to EN61000-3-12.

Integrated brake chopper

- A built-in brake chopper for 3-phase drives in the whole power range saves money and panel space.

Pulse input as speed reference

- FC 280 offers the capability to convert pulse input as a speed reference, avoiding the need to purchase an analog signal module for the PLC.

Integrated PID controller

- The built-in PID controller ensures solid process control, such as constant pressure or constant flow operation.

Integrated RFI filter

- Built-in filters not only save space, but also eliminate extra costs for fitting, wiring and material. The integrated RFI filter improves power supply quality, avoiding malfunction and improving the reliability of surrounding components.

Coated PCBs

- The printed circuit boards (PCB) are coated as standard according to 3C3 (IEC 60721-3-3) classification against corrosive gases. This protection provides high reliability in harsh environments, preventing failures and unnecessary downtime increasing lifetime of the drive.

Reliable back-up concept

- External 24 V back-up option for power supply, to keep fieldbus communication on, while disconnected from mains.

Communicative

Easy connectivity

For convenient PC connection during commissioning or service, use the integrated USB port.

Your choice of fieldbus

Communicate using your choice of process automation protocols:

- PROFIBUS
- PROFINET with dual port
- EtherNet/IP™ with dual port
- CANopen
- Modbus RTU and FC Protocol are integrated as standard

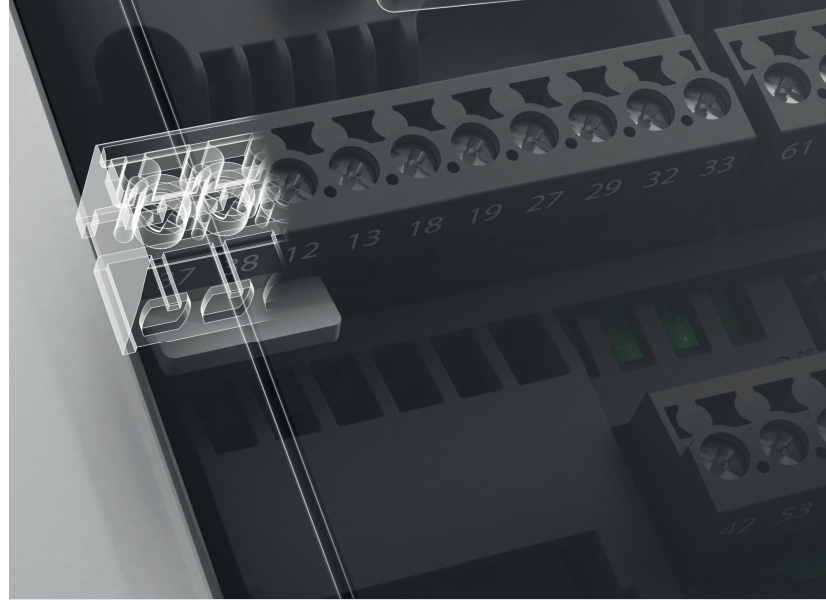

Safe

Dual-channel Safe Torque Off

The Safe Torque Off (STO) function is a component in a safety control system. STO prevents the unit from generating the energy that is required to rotate the motor, which ensures safe conditions in emergency situations. The dual-channel STO function in the VLT® Midi Drive is designed and approved suitable for the requirements of:

- IEC/EN 61508: 2010 SIL 2
- IEC/EN 61800-5-2: 2007 SIL2
- IEC/EN 62061: 2005 SILCL of SIL2
- EN ISO 13849-1: 2008 Category 3 PL d

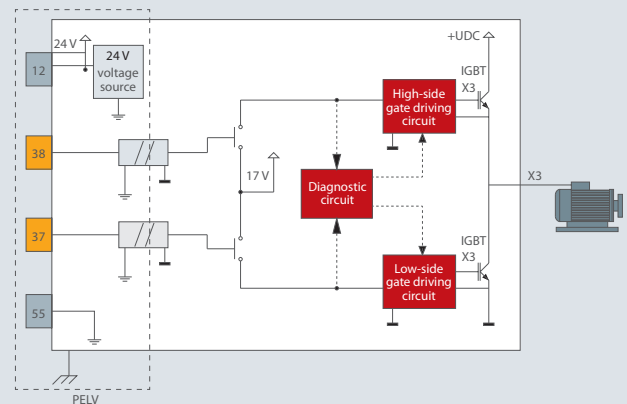

Adaptive

PM motor compatibility

- You win the freedom to choose the best high-efficiency motor for your application. The VLT® Midi Drive provides highly efficient permanent magnet (PM) motor control in open loop under VVC+ in the whole power range.

Specifications

Mains supply (L1, L2, L3)	
Supply voltage	200-240 V (-15%/+10%) 380-480 V (-15%/+10%)
Supply frequency	50/60 Hz
Displacement power factor (cos φ)	Near unity (> 0.98)
Switching frequency on input supply L1, L2, L3	Switching maximum 2 times/minute
Output data (U, V, W)	
Output voltage	0-100% of supply voltage
Switching on output	Unlimited
Ramp times	0.01-3600 s
Frequency range	0-500 Hz
Programmable digital inputs and outputs	
Digital inputs / digital outputs*	6 (7) / 1
Logic	PNP or NPN
Voltage level	0-24 V DC

One of 6 digital inputs can be configured as digital output or pulse output. One of analog inputs can be configured as an extra digital input, thereby bringing the quantity of digital inputs to 7.

Pulse and encoder inputs	
Pulse inputs / encoder inputs**	2/2
Voltage level	0-24 V DC

**Note: Two digital inputs can be configured as pulse inputs. One pair of inputs can be configured as encoder inputs.

Programmable analog inputs	
Analog inputs	2
Modes	1 voltage or current / 1 voltage or DI
Voltage level	0 V to +10 V (scaleable)
Current level	0/4 to 20 mA (scaleable)

Programmable analog outputs	
Analog outputs	1
Current range at analog output	0/4 to 20 mA

Programmable relay outputs	
Relay outputs	1

Approvals	
Approvals	CE, UL listed, cUL, TÜV, RCM (C-Tick)



Electric data

VLТ® Midi Drive FC 280 3 x 380-480 V AC

Enclosure IP20		K1						K2	
		PK37	PK55	PK75	P1K1	P1K5	P2K2	P3K0	
Typical shaft output	[kW]	0.37	0.55	0.75	1.1	1.5	2.2	3	
Output current									
Continuous (3 x 380-440 V)	[A]	1.2	1.7	2.2	3	3.7	5.3	7.2	
Continuous (3 x 441-480 V)	[A]	1.1	1.6	2.1	2.8	3.4	4.8	6.3	
Intermittent (60 s overload)	[A]	1.9	2.7	3.5	4.8	6.0	8.5	11.5	
Output power									
Continuous (400 V AC)	[kVA]	0.8	1.2	1.5	2.1	2.6	3.7	5.0	
Continuous (480 V AC)	[kVA]	0.9	1.3	1.7	2.5	2.8	4.0	5.2	
Maximum input current									
Continuous (3 x 380-440 V)	[A]	1.2	1.6	2.1	2.6	3.5	4.7	6.3	
Continuous (3 x 441-480 V)	[A]	1.0	1.2	1.8	2.0	2.9	3.9	4.3	
Intermittent (60 s overload)	[A]	1.9	2.6	3.4	4.2	5.6	7.5	10.1	
Additional specifications									
Max. cable cross-section Mains, motor, brake and load sharing	[mm ²] (AWG)	4 (12)							
Estimated power loss at rated maximum load ¹⁾	[W]	20.9	25.2	30.01	40.01	53	74.0	94.8	
Efficiency ²⁾	[%]	96.2	97.0	97.2	97.4	97.4	97.6	97.5	

Enclosure IP20		K2		K3	K4		K5	
		P4K0	P5K5	P7K5	P11K	P15K	P18K	P22K
Typical shaft output	[kW]	4	5.5	7.5	11	15	18.5	22
Output current								
Continuous (3 x 380-440 V)	[A]	9	12	15.5	23	31	37	42.5
Continuous (3 x 441-480 V)	[A]	8.2	11	14	21	27	34	40
Intermittent (60 s overload)	[A]	14.4	19.2	24.8	34.5	46.5	55.5	63.8
Output power								
Continuous (400 V AC)	[kVA]	6.2	8.3	10.7	15.9	21.5	25.6	29.5
Continuous (480 V AC)	[kVA]	6.8	9.1	11.6	17.5	22.4	28.3	33.3
Maximum input current								
Continuous (3 x 380-440 V)	[A]	8.3	11.2	15.1	22.1	29.9	35.2	41.5
Continuous (3 x 441-480 V)	[A]	6.8	9.4	12.6	18.4	24.7	29.3	34.6
Intermittent (60 s overload)	[A]	13.3	17.9	24.2	33.2	44.9	52.8	62.3
Additional specifications								
Max. cable cross-section Mains, motor, brake and load sharing	[mm ²] (AWG)	4 (12)			16 (6)			
Estimated power loss at rated maximum load ¹⁾	[W]	115.5	157.5	192.8	289.5	393.4	402.8	467.5
Efficiency ²⁾	[%]	97.6	97.7	98.0	97.8	97.8	98.1	97.9

VLТ® Midi Drive FC 280 3 x 200-240 V AC

Enclosure IP20		K1					K2	K3	
		PK37	PK55	PK75	P1K1	P1K5	P2K2	P3K7	
Typical shaft output	[kW]	0.5	0.74	1.0	1.5	2.0	3.0	3.7	
Output current									
Continuous (3 x 200-240 V)	[A]	2.2	3.2	4.2	6	6.8	9.6	15.2	
Intermittent (60 s overload)	[A]	3.5	5.1	6.7	9.6	10.9	15.4	24.3	
Output power									
Continuous (230 V AC)	[kVA]	0.9	1.3	1.7	2.4	2.7	3.8	6.1	
Maximum input current									
Continuous (3 x 200-240 V)	[A]	1.8	2.7	3.4	4.7	6.3	8.8	14.3	
Intermittent (60 s overload)	[A]	2.9	4.3	5.4	7.5	10.1	14.1	22.9	
Additional specifications									
Max. cable cross-section Mains, motor and brake	[mm ²] (AWG)	4 (12)							
Estimated power loss at rated maximum load ¹⁾	[W]	29.4	38.5	51.1	60.7	76.1	96.1	147.5	
Efficiency ²⁾	[%]	96.4	96.6	96.3	96.6	96.5	96.7	96.7	

VLТ® Midi Drive FC 280 1 x 200-240 V AC

Enclosure IP20		K1					K2	
		PK37	PK55	PK75	P1K1	P1K5	P2K2	
Typical shaft output	[kW]	0.5	0.74	1.0	1.5	2.0	3.0	
Output current								
Continuous (3 x 200-240 V)	[A]	2.2	3.2	4.2	6	6.8	9.6	
Intermittent (60 s overload)	[A]	3.5	5.1	6.7	9.6	10.9	15.4	
Output power								
Continuous (230 V AC)	[kVA]	0.9	1.3	1.7	2.4	2.7	3.8	
Maximum input current								
Continuous (1 x 200-240 V)	[A]	2.9	4.4	5.5	7.7	10.4	14.4	
Intermittent (60 s overload)	[A]	4.6	7.0	8.8	12.3	16.6	23.0	
Additional specifications								
Max. cable cross-section Mains, motor and brake	[mm ²] (AWG)	4 (12)						
Estimated power loss at rated maximum load ¹⁾	[W]	37.7	46.2	56.2	76.8	97.5	121.6	
Efficiency ²⁾	[%]	94.4	95.1	95.1	95.3	95.0	95.4	

¹⁾ The typical power loss is stated at nominal load conditions and expected to be within $\pm 15\%$ (tolerance relates to variations in voltage and cable conditions). Values are based on a typical motor efficiency (IE2/IE3 borderline). Motors with lower efficiency add to the power loss in the AC drive and motors with high efficiency reduce power loss. Applies for dimensioning of AC drive cooling. If the switching frequency is higher than the default setting, the power losses may rise. LCP and typical control card power consumptions are included. Further options and customer load may add up to 30 W to the losses (though typical only 4 W extra for a fully-loaded control card or fieldbus).

For power loss data according to EN 50598-2, refer to www.danfoss.com/vitenergyefficiency.

²⁾ Measured using 50 m screened motor cables at rated load and rated frequency. For energy efficiency class, see the Operating Instructions, chapter 9.4 Ambient Conditions. For part load losses, see www.danfoss.com/vitenergyefficiency.

Ordering typecode



[1] Application (character 4-6)	
280	VLT® Midi Drive FC 280
[2] Power size (character 7-10)	
PK37	0.37 kW / 0.50 HP
PK55	0.55 kW / 0.75 HP
PK75	0.75 kW / 1.0 HP
P1K1	1.1 kW / 1.5 HP
P1K5	1.5 kW / 2.0 HP
P2K2	2.2 kW / 3.0 HP
P3K0	3.0 kW / 4.0 HP
P3K7	3.7 kW / 5.0 HP
P4K0	4.0 kW / 5.5 HP
P5K5	5.5 kW / 7.5 HP
P7K5	7.5 kW / 10 HP
P11K	11 kW / 15 HP
P15K	15 kW / 20 HP
P18K	18.5 kW / 25 HP
P22K	22 kW / 30 HP

[3] AC Line Voltage (character 11-12)	
S2	1 x 200/240 V AC
T2	3 x 200/240 V AC
T4	3 x 380/480 V AC
[4] Enclosure (character 13-15)	
E20	IP20/Chassis
[5] RFI filter, terminal and monitoring options – EN/IEC 61800-3 (character 16-17)	
H1	RFI-Filter Class: Single-phase A1/B (C1) 3-phase A1 (C2)
H2	RFI-Filter, Class A2 (C3)
[6] Braking (character 18)	
X	No brake IGBT (S2 only)
B	Brake IGBT
[7] LCP Display (character 19)	
X	No LCP installed
[8] PCB Coating – IEC 721-3-3 (character 20)	
C	Coated PCB Class 3C3

[9] Mains input (character 21)	
X	No mains option
[10] Hardware option A (character 22)	
X	Standard cable entries
[11] Hardware option B (character 23)	
X	No adaptation
[12] Special version (character 24-27)	
SXXX	Latest released standard software
[13] LCP language (character 28)	
X	English, German, French, Spanish, Danish, Italian, Brazilian-Portuguese
Contact factory for other language options	
[14] Integrated fieldbus (character 29-30)	
AX	Modbus RTU
A0	PROFIBUS DP
A6	CANopen
AL	PROFINET
AN	EtherNet/IP

Please be aware that not all combinations are possible. Get help to configure your AC drive using the online configurator at: driveconfig.danfoss.com

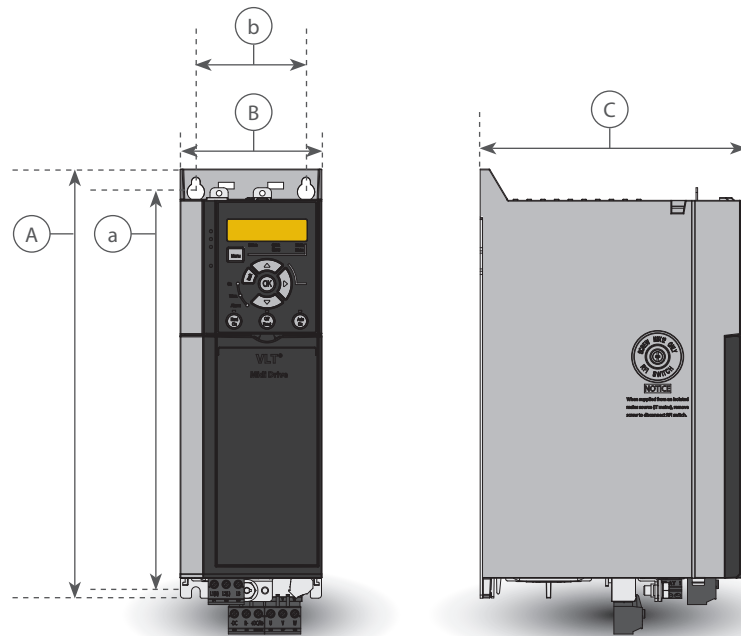

Dimensions and weights

Enclosure IP20		K1					K2			K3	K4		K5		
Power size [kW]	Single-phase 200-240 V	0.37	0.55	0.75	1.1	1.5	2.2								
	3-phase 200-240 V	0.37	0.55	0.75	1.1	1.5	2.2			3.7					
	3-phase 380-480 V	0.37	0.55	0.75	1.1	1.5	2.2	3	4	5.5	7.5	11	15	18.5	22
Dimensions [mm]	Height A	210					272.5			272.5	320		410		
	Width B	75					90			115	135		150		
	Depth C	168					168			168	245		245		
Mounting holes	a	198					260			260	297.5		390		
	b	60					70			90	105		120		
	c	5					6.4			6.5	8		7.8		
	d	9					11			11	12.4		12.6		
	e	4.5					5.5			5.5	6.8		7		
	f	7.3					8.1			9.2	11		11.2		
Weight [kg]	IP20	2.3					2.5			3.6	4.1	9.4	9.5	12.3	12.5



Integrated Fieldbuses

Available for the full product range

Fieldbus

- PROFIBUS DP V1
- PROFINET with dual port
- EtherNet/IP with dual port
- CANopen
- Modbus RTU are integrated as standard

PROFIBUS DP

Operating the AC drive via a fieldbus enables you to reduce the cost of your system, communicate faster and more efficiently, and benefit from an easier user interface.

PROFIBUS DP provides:

- Wide compatibility, a high level of availability, support for major PLC vendors, and compatibility with future versions
- Fast, efficient communication, transparent installation, advanced diagnosis and parameterization and auto-configuration of process data via GSD-file
- Acyclic parameterization using PROFIBUS DP-V1, PROFIdrive or Danfoss FC profile state machines, PROFIBUS DP-V1, Master Class 1 and 2

PROFINET

PROFINET uniquely combines the highest performance with the highest degree of openness. The PROFINET variant gives the user access to the power of Ethernet. It is designed so that many of the features from PROFIBUS can be reused, minimizing user effort to migrate PROFINET, and securing the investment in PLC program.

Other features:

- Support of DP-V1 Diagnostic allows easy, fast and standardized handling of warning and fault information into the PLC, improving bandwidth in the system

PROFINET encompasses a suite of messages and services for a variety of manufacturing automation applications.

EtherNet/IP™

Ethernet is the future standard for communication at the factory floor. EtherNet/IP™ is based on the newest technology available for industrial use and handles even the most demanding requirements. EtherNet/IP extends commercial off-the-shelf Ethernet to the Common Industrial Protocol (CIP™) – the same upper-layer protocol and object model found in DeviceNet.

Advanced features:

- Built-in high performance switch enabling line-topology, and eliminating the need for external switches
- Advanced switch and diagnosis functions
- Unicast and Multicast communication

CANopen

High flexibility and low cost are two of the “cornerstones” for CANopen. The CANopen variant is fully equipped with both high priority access to control and status of the AC drive (PDO Communication) and access to all parameters through acyclic data (SDO Communication).

For interoperability the option has implemented the DSP402 AC drive profile. This all guarantees standardized handling, interoperability and low cost.

Modbus RTU

The Modbus RTU protocol is based on the integrated RS485 (EIA-485) interface on the control card.

RS485 is a two-wire bus-interface that allows multi-drop network topology. Danfoss uses the two-wire system where the communication between master and slave is half-duplex, meaning it cannot transmit and receive at the same time.

According to the EIA-485 specification:

- A total of 32 nodes can be connected to one Modbus RTU network segment
- A total of 247 nodes in a network are supported
- Network segments are divided with repeaters



Accessories

LCP

VLT® Control Panel LCP 21 (Numeric)

Ordering number: 132B0254

VLT® Control Panel LCP Blind Cover

Ordering number: 132B0262

VLT® Control Panel LCP 102 (Graphical)

Ordering number: 130B1107

LCP Panel Mounting Kit

Ordering number for IP20 enclosure

130B1117: (Graphical) with fasteners, gasket and without LCP and with 3 m cable

132B0102: (Numerical) with fasteners, gasket and without LCP and with 3 m cable

Graphical LCP Adapter

Ordering number: 132B0281

Power Options*

VLT® Sine-Wave Filter MCC 101

VLT® dU/dt Filter MCC 102

VLT® Brake Resistors MCE 101

Accessories

VLT® Memory Module MCM 102

Ordering number: Available December 2016

VLT® 24 V DC Supply MCB 106

Ordering number: 132B0368

IP21/Type 1 conversion kit

Ordering number:

132B0335: K1

132B0336: K2

132B0337: K3

132B0338: K4

132B0339: K5

Mounting adapter

Ordering number:

132B0363: Adapter Plate, VLT® 2800 size A

132B0364: Adapter Plate, VLT® 2800 size B

132B0365: Adapter Plate, VLT® 2800 size C

132B0366: Adapter Plate, VLT® 2800 size D

*Ordering number: See relevant Design Guide



Danfoss Drives

Danfoss Drives is a world leader in variable speed control of electric motors. We aim to prove to you that a better tomorrow is driven by drives. It is as simple and as ambitious as that.

We offer you unparalleled competitive edge through quality, application-optimized products targeting your needs – and a comprehensive range of product lifecycle services.

You can rely on us to share your goals. Striving for the best possible performance in your applications is our focus. We achieve this by providing the innovative products and application know-how required to optimize efficiency, enhance usability, and reduce complexity.

From supplying individual drive components to planning and delivering complete drive systems; our experts are ready to support you all the way.

We draw on decades of experience within industries that include:

- Chemical
- Cranes and Hoists
- Food and Beverage
- HVAC
- Lifts and Escalators
- Marine and Offshore
- Material Handling
- Mining and Minerals
- Oil and Gas
- Packaging
- Pulp and Paper
- Refrigeration
- Water and Wastewater
- Wind

You will find it easy to do business with us. Online, and locally in more than 50 countries, our experts are never far away, reacting fast when you need them.

Since 1968, we have been pioneers in the drives business. In 2014, Vacon and Danfoss merged, forming one of the largest companies in the industry. Our AC drives can adapt to any motor technology and we supply products in a power range from 0.18 kW to 5.3 MW.

VLT® | VAGON®

Danfoss Drives, Ulsnaes 1, DK-6300 Graasten, Denmark, Tel. +45 74 88 22 22, Fax +45 74 65 25 80, drives.danfoss.com, E-mail: info@danfoss.com

Danfoss can accept no responsibility for possible errors in catalogues, brochures and other printed material. Danfoss reserves the right to alter its products without notice. This also applies to products already on order provided that such alterations can be made without subsequential changes being necessary in specifications already agreed. All trademarks in this material are property of the respective companies. Danfoss and the Danfoss logotype are trademarks of Danfoss A/S. All rights reserved.